



FN-642-ULADA
FN-842-ULADA
FN-1042-ULADA
NAC Power Extenders

Application Guide

(See Installation Guide for additional information)



1. General Information (Use this in conjunction with respective Installation Guide):

Hochiki FN-642-ULADA, FN-842-ULADA and FN-1042-ULADA are very versatile devices. They can be used with or without specific synchronization modules provided by some manufacturers. Multiple units can be synchronized by using either the built-in sync mode or a external synchronization module. Please note, that only notification appliances with synchronization capabilities can be synchronized. Contact signal manufacturer for more detailed information. Units can operate with either one (1) or two (2) outputs from the FACP.

2. Class A, Style Z and Class B, Style W, Y Hookups:

Fig. 2a

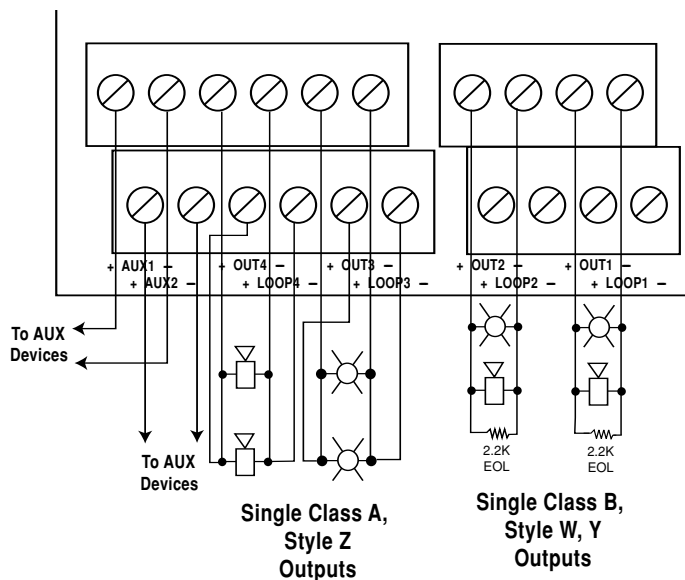

Each output 1 through 4 can be used in Class B, Style W, Y or Class A, Style Z configuration. For Class A hookups loop starts on [+ OUT -] (1 through 4) terminates on corresponding [+ RET -]. For Class B, Style W, Y hookups loop starts on [+ OUT -], terminates on 2.2k EOL.

3. Non-synchronizable NAC Appliances:

When using NAC appliances not designed to support synchronization feature, it is recommended to use separate output circuits for audible notification appliances (horns) and visual notification appliances (strobes). Set dip switches for the visual notification appliances to follow Input 1 [IN1] and for audible notification appliances to follow Input 2 [IN2]. This will allow, when using two (2) outputs from the FACP, to support silencing of audible notification appliances. When using only one (1) FACP output, set all dip switches to follow Input 1 [IN1]. The units outputs can each be set for the desired NAC drive signal, such as Code 3 or march time sequence (*Output Programming Selection Table, pg. 6*). Non-synchronizable Audible Appliances will follow the sequence, when feature is selected.

4. Triggering One (1) or More NAC Power Extenders from an FACP:

One (1) or more units can be triggered. Connect the output of the FACP module to Input 1 and Input 2. Terminate the input circuits with the EOL, connecting it to terminals marked [RET+ and RET-], or continue the input circuits to the next NAC Power Extender.

In case FACP does not have any synchronization capabilities and the sync mode is not used, the notification appliance synchronization will not be provided.

Fig. 4a

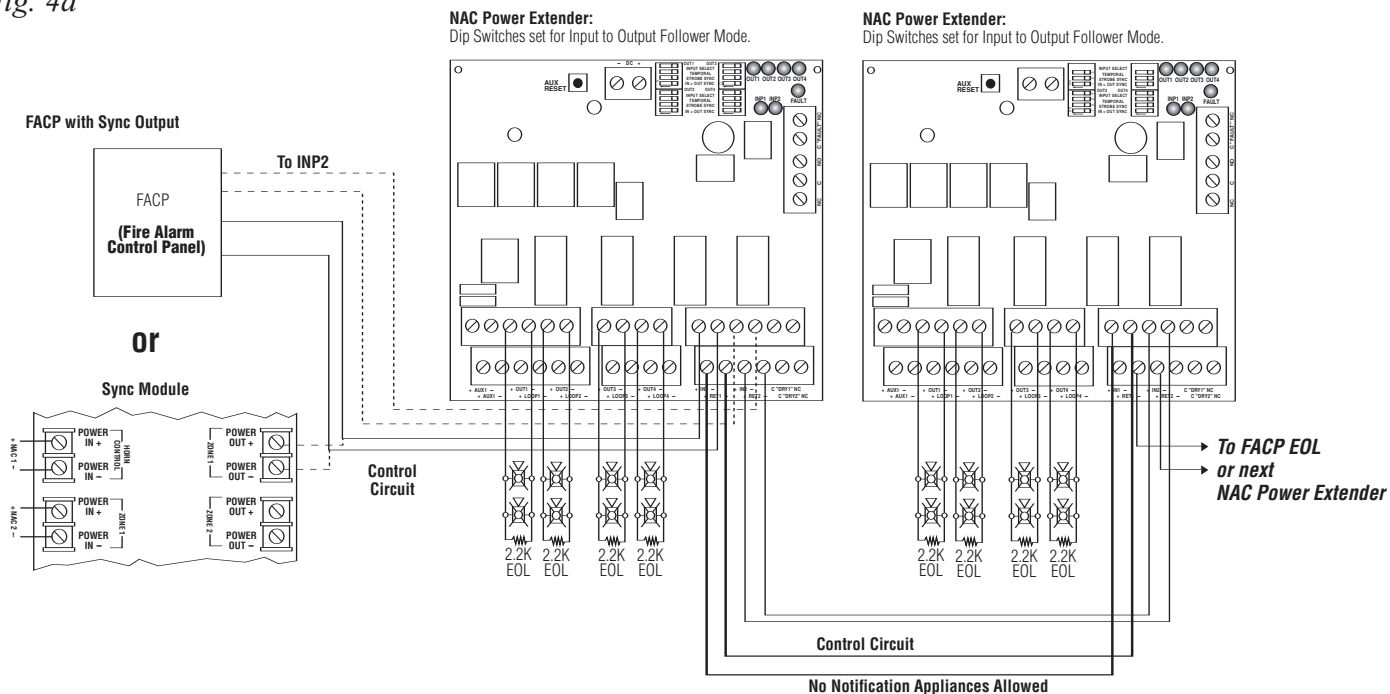

Caution: Do not connect any notification appliances on the control circuit interconnecting FACP outputs (sync module outputs) and inputs of NAC Power Extenders. Applications that do not employ synchronization module or FACP with synchronization protocol will not provide NAC synchronization between NAC Power Extenders.

5. Synchronizing NAC Power Extender Using Built-in Sync Protocol:

FN-642/842/1042-ULADA have built-in protocols to support Amseco, Faraday, Gentex® and System Sensor®, CooperWheelock® two-wire synchronizable devices, therefore an external sync module is not required (*Output Programming Selection Table, pg. 6*). In these modes, Input 1 is always used to activate visual notification appliances (strobes), and Input 2 is used to activate and silence audible notification appliances (strobes).

Note: Input 1 has to be activated in all the configurations.

Fig. 5a

For continuous loop circuit use 2.2K EOL.

NAC Power Extender:

Dip Switches set for desired Sync Protocol (ex. Gentex®, System Sensor®, Faraday or Amseco, CooperWheelock®).

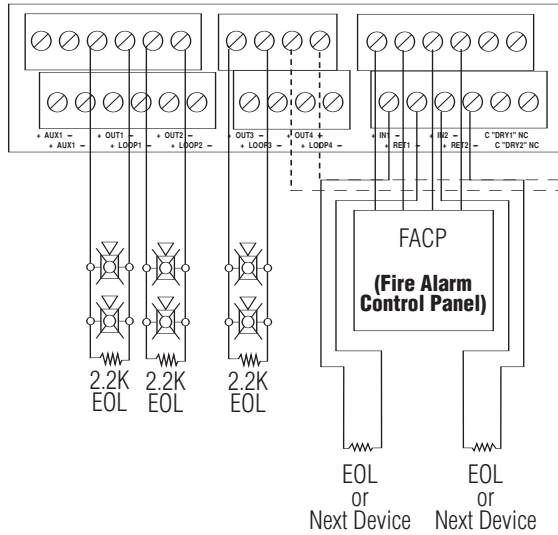

NAC Power Extender:

Dip Switches set for desired Sync Protocol (ex. Gentex®, System Sensor®, Faraday or Amseco, CooperWheelock®).

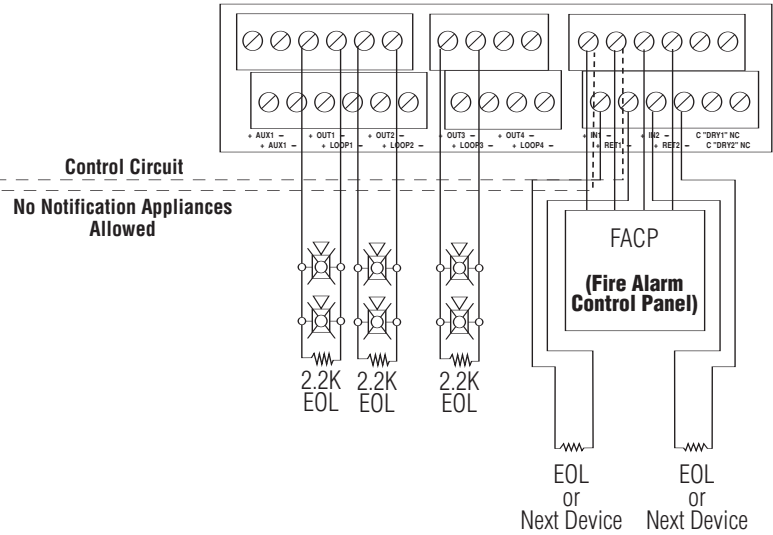

6. Using Single FACP Output.

When only one FACP output is available, you may connect both Input1 and Input2 to it. Wire [RET1+ and RET1]- to [INP2+ and INP2-]. Both Visual and Audible appliances will be activated simultaneously (*Fig 6a*).

Fig. 6a

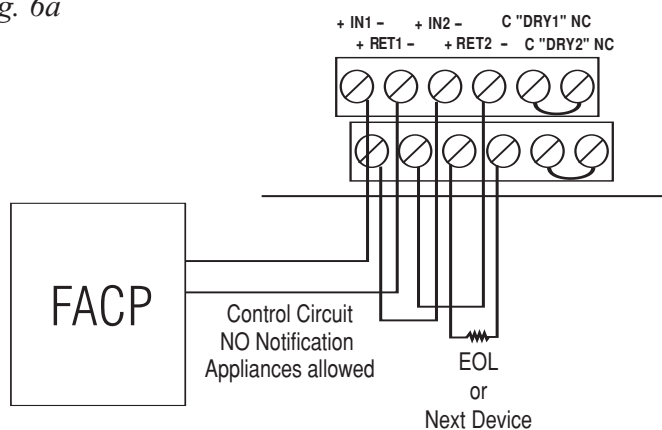

Output Programming Selection Table:
Outputs must be programmed independently [OUT1 - OUT4]

Function	Switch Position		Description
	ON	OFF	
Input to Output Follower Mode	1	2, 3	Output follows signal it receives from the corresponding input (i.e. FACP Sync module - maintains synchronization of notification appliance circuit.
Temporal Code 3 Mode	3	1, 2	Enables Temporal Code 3 signal generation output. This mode is activated by a steady or a pulsing input.
Steady Mode	—	1, 2, 3	A steady output signal will be generated. This mode is activated by a steady or pulsing input.

For the above modes Dip Switch 4 determines which Input controls the corresponding output:
 Switch 4 in the ON position causes output(s) to be controlled by input 1.
 Switch 4 in the OFF position causes output(s) to be controlled by input 2.

(AL842LGK Board)
Output Dip Switches

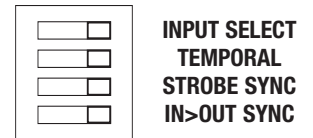

Sync Mode Selection Table:

Function	Switch Position		Description
	ON	OFF	
Amseco Sync Mode*	1, 3, 4	2	This mode is designed to work with the Amseco series of horns, strobes, and horn/strobes to provide a means of synchronizing the Temporal-coded horns, synchronizing the flash timing of the strobe, and silencing the horns of the horn/strobe combination over a two-wire circuit while leaving strobes active.
Faraday Sync Mode*	2, 4	1, 3	This mode is designed to work with the Faraday series of horns, strobes, and horn/strobes to provide a means of synchronizing the Temporal-coded horns, synchronizing the flash timing of the strobe, and silencing the horns of the horn/strobe combination over a two-wire circuit while leaving strobes active.
Gentex® Sync Mode* <small>Gentex is a registered trademark of Gentex Corporation.</small>	1, 2, 3, 4	—	This mode is designed to work with the Gentex® Commander GOS and ST/HS series of horns, strobes, and horn/strobes to provide a means of synchronizing the Temporal-coded horns, synchronizing the flash timing of the strobe, and silencing the horns of the horn/strobe combination over a two (2)-wire circuit while leaving strobes active.
System Sensor® Sync Mode* <small>System Sensor is a registered trademark of Honeywell.</small>	1, 2, 4	3	This mode is designed to work with the SpectrAlert™ series of horns, strobes, and horn/strobes to provide a means of synchronizing the Temporal-coded horns, synchronizing the one-second flash timing of the strobe, and silencing the horns of the horn/strobe combination over a two-wire circuit while leaving strobes active.
CooperWheelock Sync Mode* <small>CooperWheelock is a registered trademark of CooperWheelock.</small>	2, 3, 4	1	This mode is designed to work with the CooperWheelock series of horns, strobes, and horn/strobes to provide a means of synchronizing the Temporal-coded horns, synchronizing the one-second flash timing of the strobe, and silencing the horns of the horn/strobe combination over a two-wire circuit while leaving strobes active.

Note: The FN-642-ULADA, FN-842-ULADA, and FN-1042-ULADA will only synchronize horns, horn strobes and strobes that contain synchronization capability. Contact signal manufacturer for more detailed info. The same synchronization mode must be selected for all outputs.

Notes:

Notes: