

ALG-V PHOTOELECTRIC SMOKE SENSOR



Shown without base

STANDARD FEATURES

- Low Profile - Only 1.97" high, including base
- Simple and reliable device addressing method
- Automatic compensation for sensor contamination
- Built-in optical fire test feature
- Uses the noise immune Digital Communication Protocol (DCP), which utilizes interrupts for fast response to fires

SPECIFICATIONS

Operating Voltage	17-41 VDC
Current Consumption Standby	Normal: 390µA (typical)
Average when Polled Alarm	2mA 8mA
Transmission Method	DCP - <i>Digital Communication Protocol</i>
Maximum Humidity	95% RH Non-Condensing
UL Ambient Installation	32°F to 100° F
Temperature Range	(0° C to 37.8° C)
Operating Temperature Range	14°F to 122° F (-10° C to 50° C)
Air Velocity Range	0-4000 fpm
Color & Case Material	Bone PC / ABS Blend
Weight	3.4oz (5.1 oz. with 4" base)
Bases	4" YBN-NSA-4 6" HSB-NSA-6

Specifications subject to change without notice.

APPLICATION

The HOCHIKI America ALG-V Photoelectric Smoke Sensor is particularly suited to detecting optically dense smoke typical of fires involving materials such as soft furnishings, plastic, foam or other similar materials which tend to smoulder and produce large visible smoke particles. Hochiki's unique design allows fast response to flaming fires as well as smoldering fires while eliminating false alarms.

OPERATION

The detection chamber consists of a light emitting diode (LED) and photodiode arrangement. The chamber is designed such that light emitted by the LED cannot normally reach the photo diode. In the event of fire, particles of smoke enter the chamber and scatter the light. As the smoke level increases, the scattering effect increases, causing more light to hit the photo- diode. The chamber contains a unique baffle design which allows smoke to enter the chamber while preventing external light from affecting the photodiode. The photodiode input level is sampled to sense smoke density.

When the smoke density exceeds a preset threshold the sensor transmits an interrupt to the fire control panel indicating a fire condition. The fire alarm control panel can adjust the sensor threshold to compensate for contamination.

Up to 127 devices are permitted on each loop. A sensor address can be set by a hand held programming unit. The sensor mounts to an electronics free base and incorporates a locking mechanism for secure installation. The base provides mounting slots, terminals for field wiring and a third contact for a remote indicator/LED. The sensor incorporates dual LED's for easy viewing of sensor status.

ENGINEERING SPECIFICATIONS

The contractor shall furnish and install where indicated on the plans, photoelectric sensors HOCHIKI America Model ALG-V. The combination sensor head and twist lock base shall be UL listed compatible with a UL listed fire alarm control panel.

PRODUCT LISTINGS

SIGNALING



S1383



APPROVED
3022559

MEA

NYC Department
of Building
284-91-E Vol. 4



California
State Fire
Marshal

7272-0410:149

Continued on back.

Hochiki America Corporation

7051 Village Drive, Suite 100 Buena Park, CA 90621-2268
Phone: 714/522-2246 Fax: 714/522-2268
Technical Support: 800/845-6692 or technicalsupport@hochiki.com



Find latest revision at www.hochiki.com



ENGINEERING SPECIFICATIONS, *continued*

The base shall permit direct interchange with the HOCHIKI America AIE-EA ionization type smoke sensor, and the ATG-EA heat sensor.

The sensitivity of the sensor shall be capable of being measured by the control panel.

The vandal-resistant, security locking feature shall be used in those areas as indicated on the drawing. The locking feature shall be optional and can be implemented when required.

BASES

The HOCHIKI America YBN-NSA-4 and the HSB-NSA-6 mounting bases are electronics free and are a simple rugged design with screw terminals for wiring connections. A common mounting base allows sensor interchange and maintains loop continuity when sensors are removed. A simple anti-tamper head locking system is provided which is enabled by removing a small plastic tab on the back of the sensor. Once locked, the head can be removed using a small diameter screw driver.

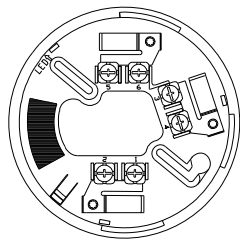

YBN-NSA-4 Base

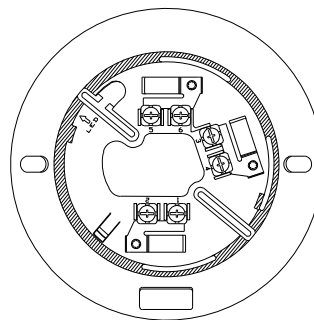

HSB-NSA-6 Base

TYPICAL WIRING DIAGRAMS

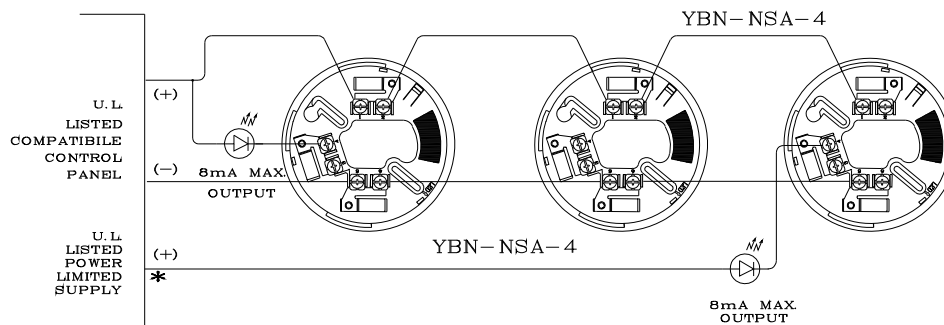

* - OPTIONAL WIRING CONFIGURATIONS FOR REMOTE OUTPUT
HSB-NSA-6

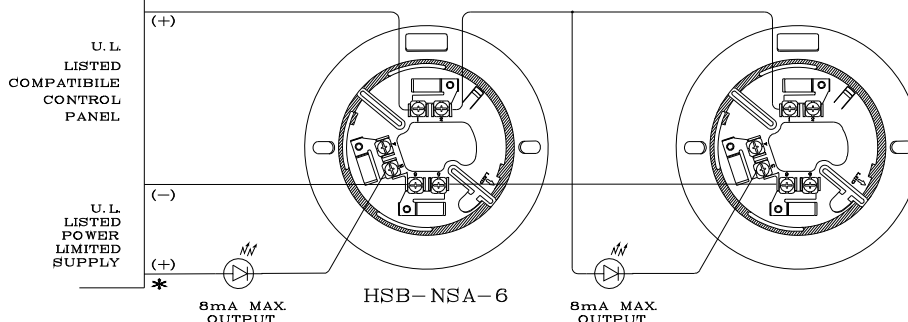

NOTE: Fire alarm control panel compatibility is required for DCP products.

State-of-the-art communications protocol, DCP, allows system components (DCP sensors AIE-EA, ALG-V and ATG-EA, bases and modules), to be used concurrently in a system's signal conditioning loop.