

SLR-835B DIRECT-WIRE PHOTOELECTRIC SMOKE DETECTOR



Shown with Trim Ring

SPECIFICATIONS

Light Source	GaAIs Infrared LED
Operating Voltage	Nominal: 12 VDC or 24 VDC
Working Voltage	8.0 - 35.0 VDC (35.0 VDC Max)
Wave Form	Filtered DC 15% Ripple Max.
Alarm Current	150mA Maximum
Surge Current	200µA Maximum (2 wire)
Average Stand-By Current	38µA AVG @12 VDC 55µA AVG @24 VDC 70µA AVG @35 VDC
Ambient Temperature	32° F - 120° F (0° C - 49° C)
Sensitivity Test Feature	Automatic Sensitivity Window Verification Test
Compatibility Identifier	HD-6
Order Codes	
	2-Wire Detector & Trim Ring
	Bone SLR-835B-2
	White SLR-835B-2W
	4-Wire Detector & Trim Ring
	Bone SLR-835B-4
	White SLR-835B-4W

Specifications subject to change without notice.

STANDARD FEATURES

- Low Profile - Only 2.0" High
- 2 or 4 Wire Models
- Highly Stable Operation, RF/Transient Protection
- Two built-in power/sensitivity supervision/alarm LED's
- Non-Directional Smoke Chamber
- Vandal Resistant Security Locking Feature
- Removable smoke labyrinth for cleaning or replacement
- Automatic Sensitivity window verification function meets outlined requirements in NFPA 72, Inspection, Testing and Maintenance

APPLICATION

The HOCHIKI America SLR-835B Series can be used in all areas where Photoelectric Smoke Detectors are required. It is suited for smoldering or flaming fires.

OPERATION

The SLR-835B Series photoelectric smoke detector utilizes two bicolored LED's for indication of status. In a normal standby condition the LED's flash Green every 3 seconds. When the detector senses that its sensitivity has drifted outside the UL listed sensitivity window the LED's will flash Red every 3 seconds. When the detector senses smoke and goes into alarm the status LED's will latch on Red.

The unit is comprised of an LED light source and silicon photo diode receiving element. In a normal standby condition, the receiving element receives no light from pulsing light source. In the event of fire, smoke enters the detector and light is reflected from the smoke particles to the receiving element. The light received is converted to an electronic signal. Signals are processed

Continued on back.

PRODUCT LISTINGS

Underwriters Laboratories: S1383
Factory Mutual: 3007144
CSFM #: 7272-0410:107

OPERATION, *continued*

in the comparator, and when two consecutive signals exceeding the basic level are received within a specific period of time, the time delay circuit triggers the SCR switch to activate the alarm signal. The status LED lights continuously during alarm period.

ENGINEERING SPECIFICATIONS

The contractor shall furnish and install where indicated on the plans HOCHIKI America SLR-835B direct-wire photoelectric smoke detectors. The detector shall be UL listed compatible (2-wire model) with a UL listed fire alarm panel.

The smoke detector shall have green flashing status LED's for visual supervision. When the detector is actuated, the flashing LED's will turn red and latch on steady. The detector may be reset by actuating the control panel reset switch.

The detector shall have a sensitivity window verification feature. If the sensitivity of the detector drifts outside its approved window the LED's will flash red to indicate an out of sensitivity condition.

The vandal resistant, security locking feature shall be used in those areas as indicated on the drawing. The locking feature shall be field selectable.

It shall be possible to perform a functional test of the detector without the need of generating smoke. The method shall simulate effects of products of combustion in the chamber to ensure testing of detector circuits.

Voltage and RF transient suppression techniques shall be employed to minimize false alarm potential.

WIRING DIAGRAMS

2-Wire Wiring Diagram

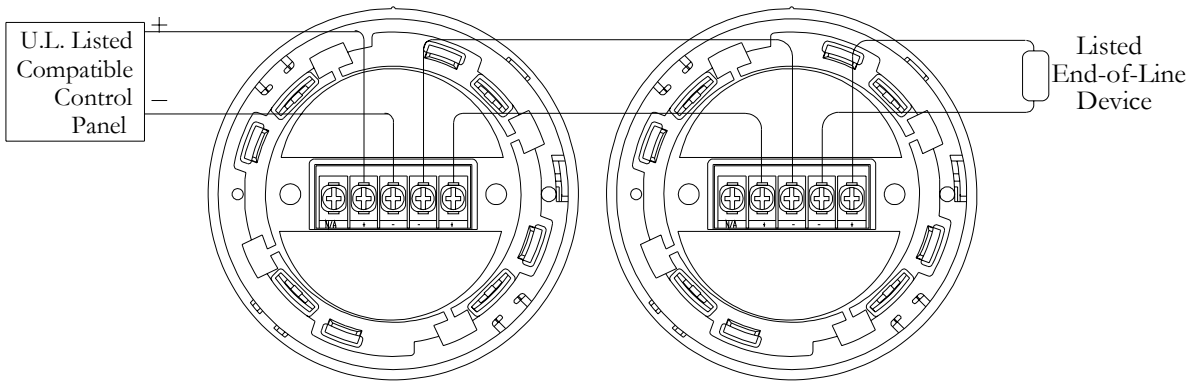

4-Wire Wiring Diagram

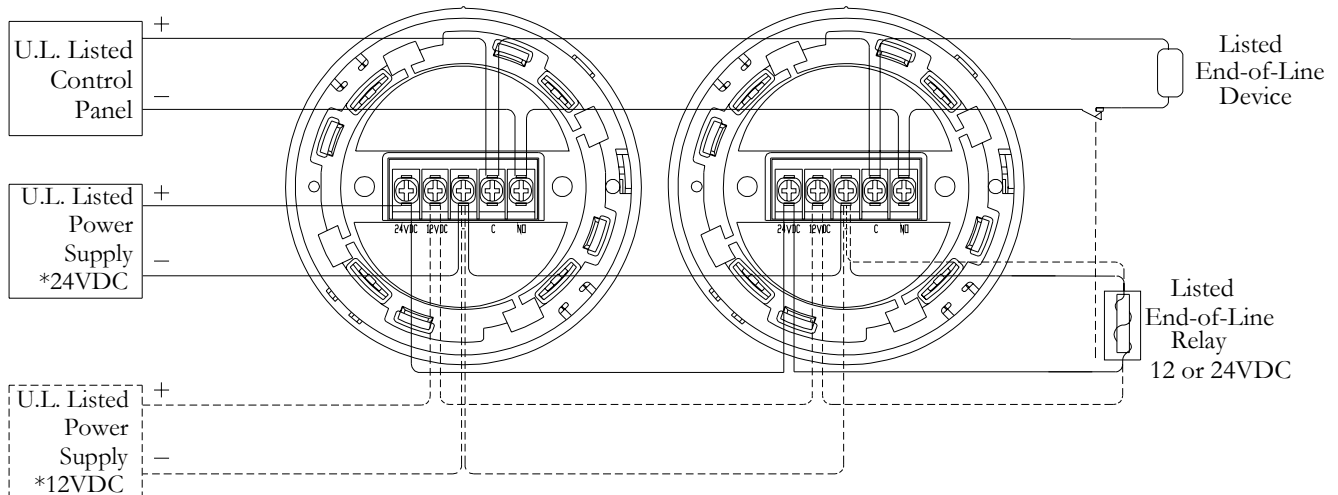

* Use either 12 OR 24VDC . They cannot be used simultaneously.