



INSTALLATION INSTRUCTIONS FOR DCP-FRCME-EEPROM FAST RESPOND CONTACT MONITORING MODULE

The information contained in this installation instruction is a quick reference guide. For detailed system information refer to the panel manufacturers installation manual. This instruction is generic and will not address specific programming procedures.

GENERAL DESCRIPTION:

This instruction applies to the DCP EEPROM Fast Response Contact Monitoring Module (FRCME) which is to be connected to a DCP Signaling Line Circuit (SLC). Typical applications are manual pull stations, water flow devices or any dry contact alarm device, either N/O or N/C contacts can be monitored.

MOUNTING REQUIREMENTS:

The DCP FRCME Module has two mounting options. The FRCME-4 is shown in Fig. 2, the FRCME-S is shown in Fig. 3. All the modules will follow Fig.4 for wiring connections.

WIRING:

NOTE: All wiring must conform to local codes, ordinances and regulations.

- 1) Install module wiring in accordance with the job drawings and appropriate wiring diagram (see Fig. 4).
- 2) Secure the module to a U.L. listed electrical box (supplied by installer) as shown in Fig. 2, 3.
- 3) The address must be set on the FRCME-4 before the cover plate is attached (see Fig. 1).

FRCME-4 MODULE ADDRESS PROGRAMMING CONNECTION AND INDICATOR

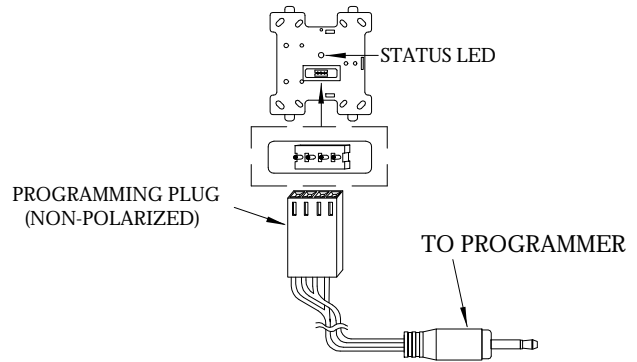

FIGURE 1.
FRCME-4 PROGRAMMING CONNECTIONS

CAUTION !!!
TO ENSURE PROPER OPERATION CONNECT THIS MODULE TO A COMPATIBLE FIRE CONTROL PANEL ONLY. REFER TO PANEL INSTRUCTIONS FOR PROPER CONNECTION AND COMPATIBILITY.

CAUTION !!!
If this module will be installed in an existing operational system, inform the operator and local authority that the system will be temporarily out of service. Disconnect power to the control panel before installing the module.

Note:

Radio Frequency Interference and Electro-Magnetic Interference are sources of noise that can adversely affect the fire alarm systems installation. When installing fire alarm system devices, avoid placing devices or wiring close to potential noise sources such as:

- Transmitters or antennas;
- Ballast lighting;
- Electrical motors;
- Large power transformers;
- Large machines.

Avoid running SLC circuit in the same conduit as power lines. Utilize twisted pair and shielded wire in environments where excessive noise is expected.

TO PROGRAMMER

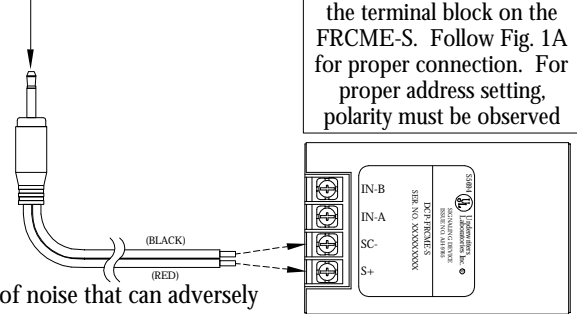

FIGURE 1A.
FRCME-S PROGRAMMING CONNECTIONS

SPECIFICATIONS

Absolute Maximum Applied Voltage	S, SC: 41 VDC
Supply Voltage Nominal	S, SC: 33 VDC
Average Current Consumption	550 μ A (Typical)
Maximum Current Consumption	Surge current: 30mA (in 5 ms.) Alarm and response: 30mA (in 20 ms.) No Alarm and no response: 660 μ A
End of Line Device for Input	U.L.listed EOL device Part No. 0400-01046 (10K OHM 1/4W)
Operating Temperature Range	0°C (32°F) ~ 49°C (120°F)
Storage Temperature	-30°C (-22°F) ~ 70°C (158°F)
Max relative humidity	Up to 90% RH non-condensing
Dimensions	4.2"W X 4.7"H X 1.4"D
Weight	Approximately 3.0 ounces
Environment	Indoor use only
Visual Indicator (status LED)	bi-color LED - Green and Red Color and mode - selected and programmed by Control Panel's software (pulsing, steady, etc.)

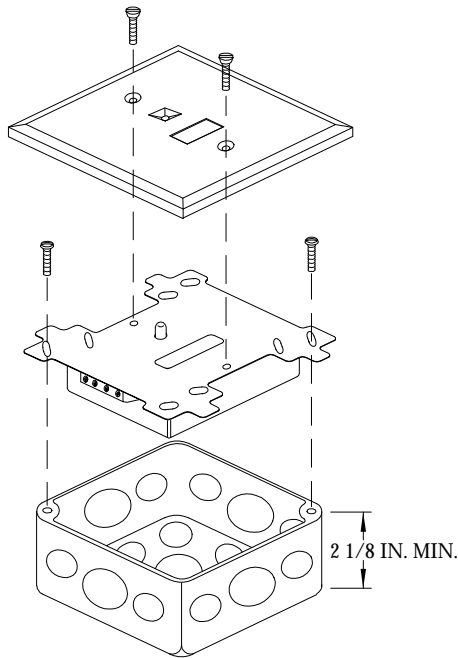

FIGURE 2
EXPLODED VIEW OF THE
FRCME-4 MOUNTING OPTION

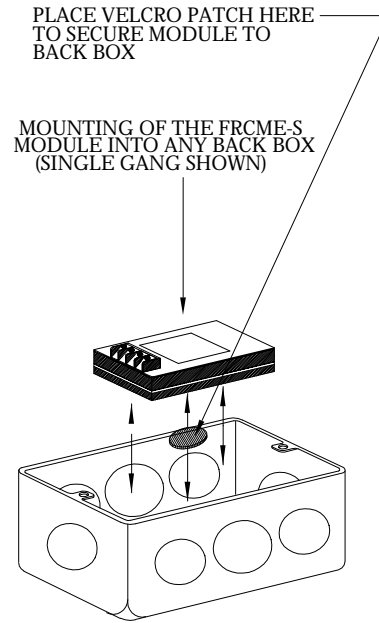

FIGURE 3
EXPLODED VIEW OF MOUNTING
OPTION USING FRCME-S

CAUTION!!!
DO NOT CONNECT MORE THAN ONE N/C CONTACT TO A MODULE!!!

INITIATING DEVICE CIRCUIT (IDC) - NFPA STYLE B (FOR WIRING LENGTH REFER TO TABLE 1)

TABLE 1: WIRING LIMITATIONS

Maximum Distance Between Module and EOL Device	
14 AWG	1500 Ft.
16 AWG	900 Ft.
18 AWG	550 Ft.

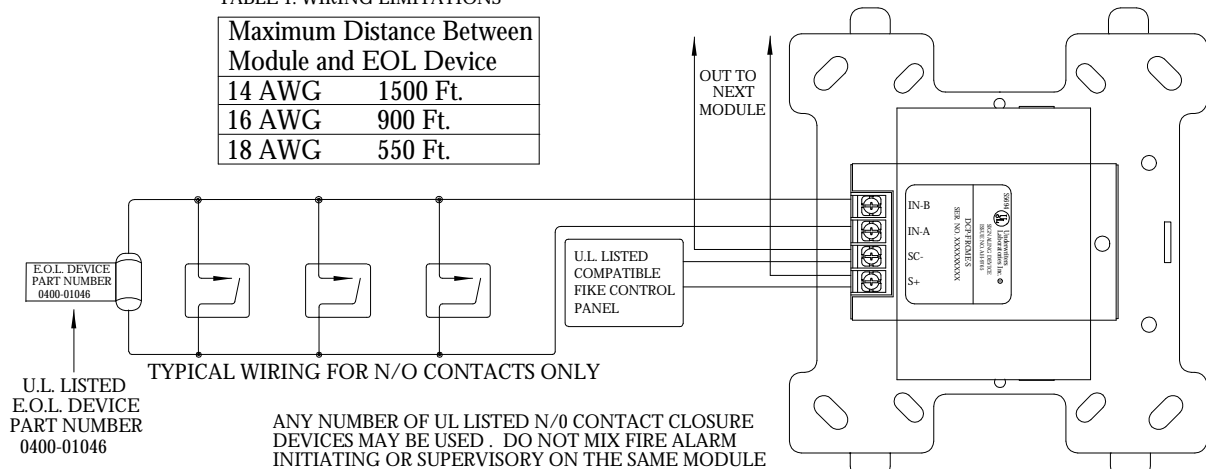

FIGURE 4.
TYPICAL WIRING DIAGRAM EXAMPLE, CONNECTED
TO A COMPATIBLE LISTED CONTROL PANEL

ALL WIRING SHOWN IS SUPERVISED
AND INHERENTLY POWER LIMITED.

One Year Limited Warranty

Hochiki America (HA) warrants its digital communication modules to be in conformance with its own plans and specifications and to be free from defects in materials and workmanship under normal use and service for a period of one (1) year from date of delivery. All warranties are void and HA is not obligated to repair or replace equipment which has been repaired by others, abused, improperly installed, altered or otherwise misused or damaged or exposed to conditions outside the products specifications in any way. HA will not be responsible for any dismantling, reassembling or re-installation charges. Please contact HA's Sales department for proper procedure for claims and return of merchandise. This warranty is in lieu of all other warranties expressed or implied.