

## INSTALLATION INSTRUCTIONS FOR THE DUCT SMOKE DETECTOR

These are Installation Instructions (DWG.# HA-06-073) for the DH-98 Duct Housing customized as follows:

- DH-98-I Duct Housing with the SIJ-24DH Conventional Ionization Smoke Detector
- DH-98-P Duct Housing with the SLR-24DH Conventional Photoelectric Smoke Detector
- DH-98-HVI High Voltage Duct Housing with the SIJ-24DH Conventional Ionization Smoke Detector
- DH-98-HVP High Voltage Duct Housing with the SLR-24DH Conventional Photoelectric Smoke Detector
- DH-98-A Duct Housing with the ALG-DH Analog Photoelectric Smoke Sensor\*
- DH-98-AR Duct Housing with the ALG-DH Analog Photoelectric Smoke Sensor & Relays\*

\*These products are compatible exclusively with fire alarm control panels that utilize Hochiki's protocol, DCP.

### I. LOCATION REQUIREMENTS

#### Duct Smoke Detector Location

**Requirements:** To prevent false alarms the detectors should not be mounted in areas of extreme high or low temperatures, in areas where high humidity exist, or in areas where duct air may contain gases or excess dust. The duct detector should, when possible, be located a minimum of six duct widths downstream from a source of turbulence (bends, inlets, or deflection plates). At these locations, air flow is less turbulent and the air/smoke mixture should be more homogenous. Refer to NFPA 90A, 72, and 101 for more information. See Figure 1A and 1B.

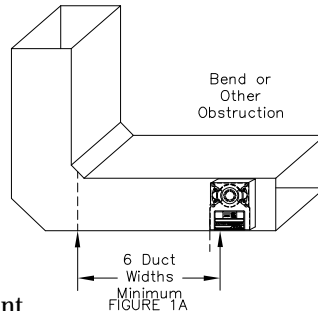

**Exception:** Where it is physically impossible to locate the duct detector accordingly, the duct detector can be positioned closer than six duct widths, but as far as possible from inlets, bends, or deflection plates.

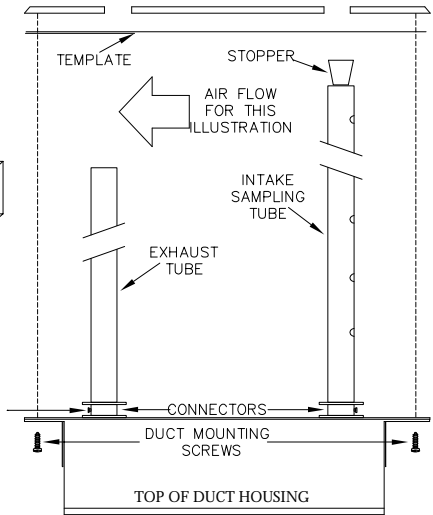

FIGURE 1B: DUCT HOUSING MOUNTING

### II. MOUNTING THE DETECTOR

#### A. DUCT PREPARATION

1. Remove paper backing from mounting template AP 121 (packaged in installation kit) and affix to duct at desired location.
2. Using template as a guide, drill 4 mounting holes (3/32" diameter) for duct mounting screws (4 #12 x 1/2" sheet metal screws packaged in installation kit). Drill or punch holes for sampling tubes in air ducts (1-3/8" diameter), using template as a guide. Clean all holes.

#### B. VERIFY AIR FLOW AND DIRECTION

The Duct Detectors are designed for use in ducts where the air velocities are from 300 to 4000 feet per minute. Verify this by checking specifications of installation and if necessary, use an Alnor Model 6000P velocity meter (or equivalent) to check the air velocity. See Figure 2 for sampling tube orientation to air flow direction.

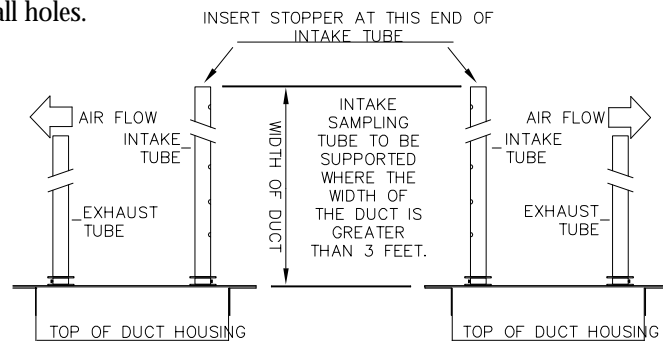

FIGURE 2 SAMPLING TUBE ORIENTATION

#### C. SAMPLING TUBE ASSEMBLY (See Figure 2)

The sampling tubes may be ordered to a desired length or ordered in one of 3 standard lengths and cut per requirements. The intake sampling tube consists of a piece of steel piping with a series of holes drilled the entire length of the tube and should extend the entire width of the duct. The holes must be facing into the air flow (see Figure 2). The exhaust tube consists of a piece of steel piping approximately 7-1/2" long.

INTAKE SAMPLING TUBES STANDARD LENGTHS:	STS-2.5	For duct widths of 1.0' to 2.5'
	STS-5.0	For duct widths of 2.5' to 5.0'
	STS-10.0	For duct widths of 5.0' to 10.0'

1. Cut the intake sampling tube to the desired length.
2. Firmly insert the stopper (packaged in installation kit) in the end of the INTAKE sampling tube.

**D. MOUNT SAMPLING TUBES** (See Figure 2)

1. Sampling tube connectors are equipped with set screws, which allow the tubes to be mounted only in directions shown in Figure 2. Establish proper orientation considering airflow direction.
2. Insert intake and exhaust tubes into connectors, align set screw to set screw hole in tubes and tighten firmly.

**E. MOUNT THE DUCT HOUSING** (See Figure 1B & 2)

Move duct housing/sampling tube assembly to desired location. Use 4 mounting screws (4 #12 x 1/2" sheet metal screws, packaged in installation kit) to secure the housing to the air duct.

**F. VERIFY AIR SAMPLING** (See Figure 3)

To verify proper sampling of air, use a Dwyer Model 4000 differential pressure gauge (or equivalent). See Figure 3 for gauge connections. The pressure differential between input sampling tube and exhaust tube should be greater than 0.01" of water and less than 1.2" of water.

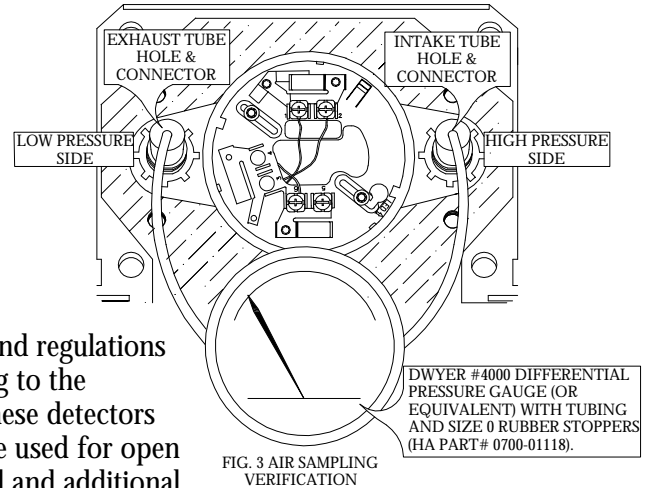

**III. ELECTRICAL INSTALLATION**

**A. GENERAL INFORMATION**

Wiring must conform to applicable local codes, ordinances and regulations covering these types of devices. Wire the detectors according to the engineering drawings for the particular job requirements. These detectors are not intended for open area protection, nor should they be used for open air protection. Refer to NFPA 90A and NFPA 72 for general and additional information on Duct Smoke Detectors concerning operation and installation. Terminals are suitable for up to #14 gauge wire.

**B. DETECTOR WIRING**

1. With power source de-energized and the smoke detector not installed, wire all connections per engineering drawings. Refer to the applicable figures below depending on your duct housing model number.
2. With all wiring in place, install the detector head.
3. Energize the duct detector.

**C. TESTING THE INSTALLATION**

*Models DH-98-I and DH-98-HVI:*

With the duct housing cover removed, place the magnet (HA Part #0700-01117) on the detector as shown in Figure 4 for approximately six (6) seconds. The detector should not alarm. Place the magnet on the opposite side (Figure 5) for another six (6) seconds. The detector LEDs should illuminate and the duct housing should go into alarm. This test will verify that the detector is within its intended limits.

*Models DH-98-P and DH-98-HVP:*

The SLR photoelectric detector has a built-in sensitivity window verification feature. If the detector is within its calibrated sensitivity range the detector LEDs will flash Green in standby or normal operation. If the detector drifts outside its sensitivity range the LEDs will flash Red to indicate an out of sensitivity condition.

*NOTE: Any of the DH-98-I, DH-98-P, DH-98-HVI or the DH-98-HVP detectors may be placed into alarm by placing the magnet (HA Part #0700-01117) as shown in Figure 6.*

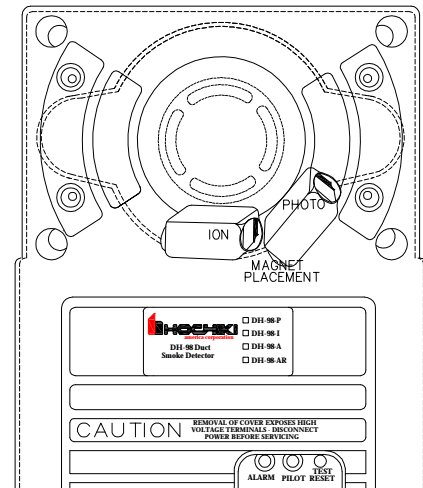
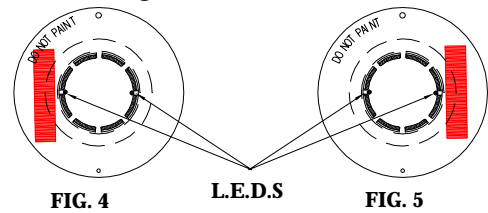

Models DH-98-A and DH-98-AR

These duct sensors are analog addressable and can be calibrated by a U.L. Listed analog control panel. See the FACP Installation Instructions for specific directions.

Note: All duct detector models can be tested with actual smoke. Remove the duct detector cover. Test the detector head by lighting a piece of cotton clothesline, and placing it approximately 3 inches from the detector head. Blow across the lit end of the clothesline toward the detector. The LEDs on the detector should illuminate within one minute. After performing this test sequence, reinstall the duct detector cover.

D. WIRING DIAGRAMS - DH-98-I, DH-98-P, DH-98-HVI and DH-98-HVP

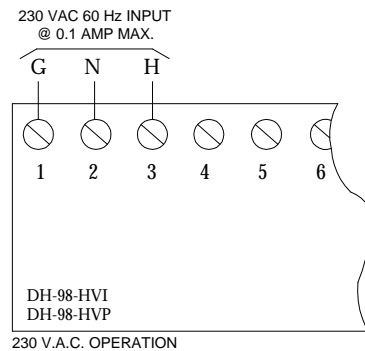
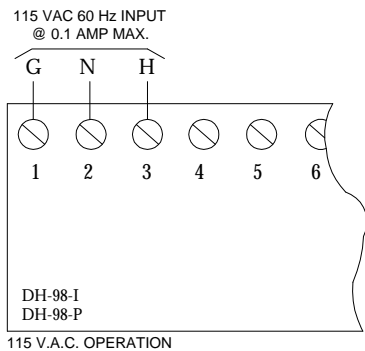
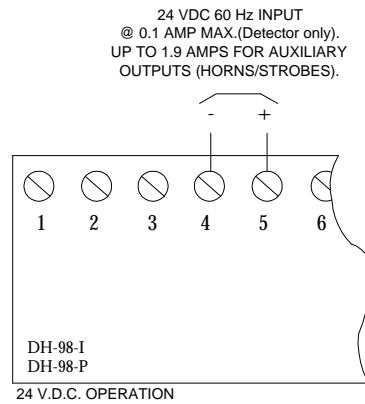
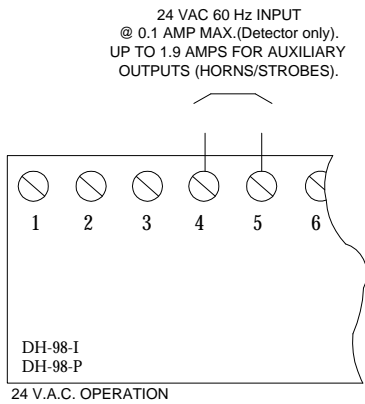
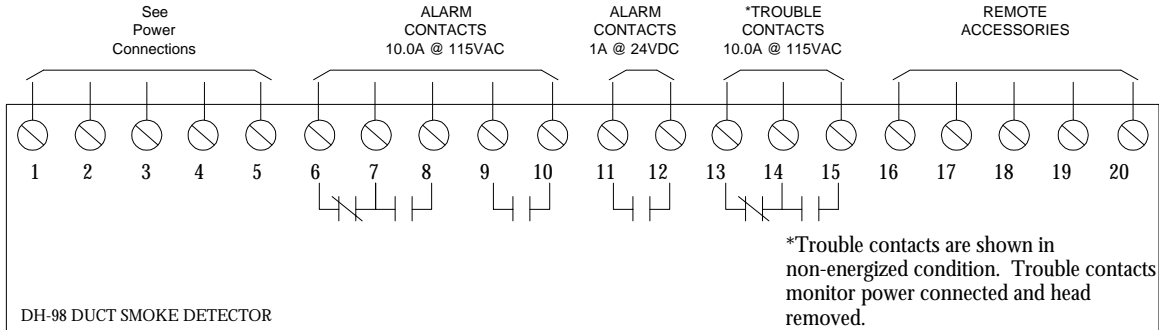

### III. ELECTRICAL INSTALLATION, continued

#### D. WIRING DIAGRAMS, continued

##### DH-98-A WIRING DIAGRAM

The DH-98-A and DH-98-AR are not self-contained sensors.

This product is compatible only with fire alarm control panels that utilize Hochiki's Digital Communications Protocol, DCP. For example the Fike Cheetah Panel.

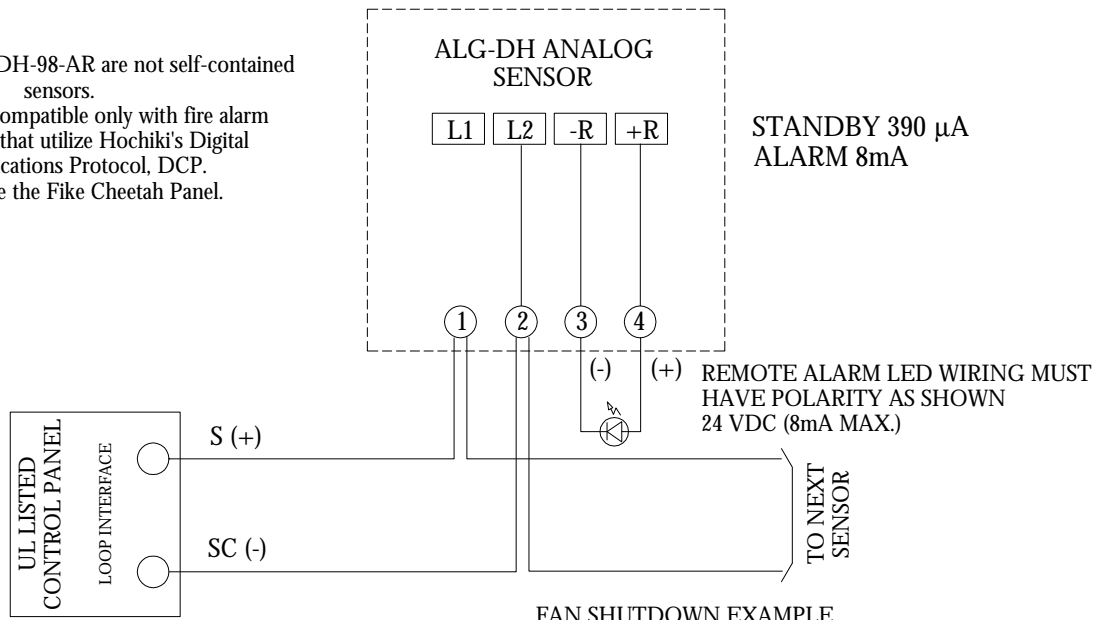

##### DH-98-AR WIRING DIAGRAM

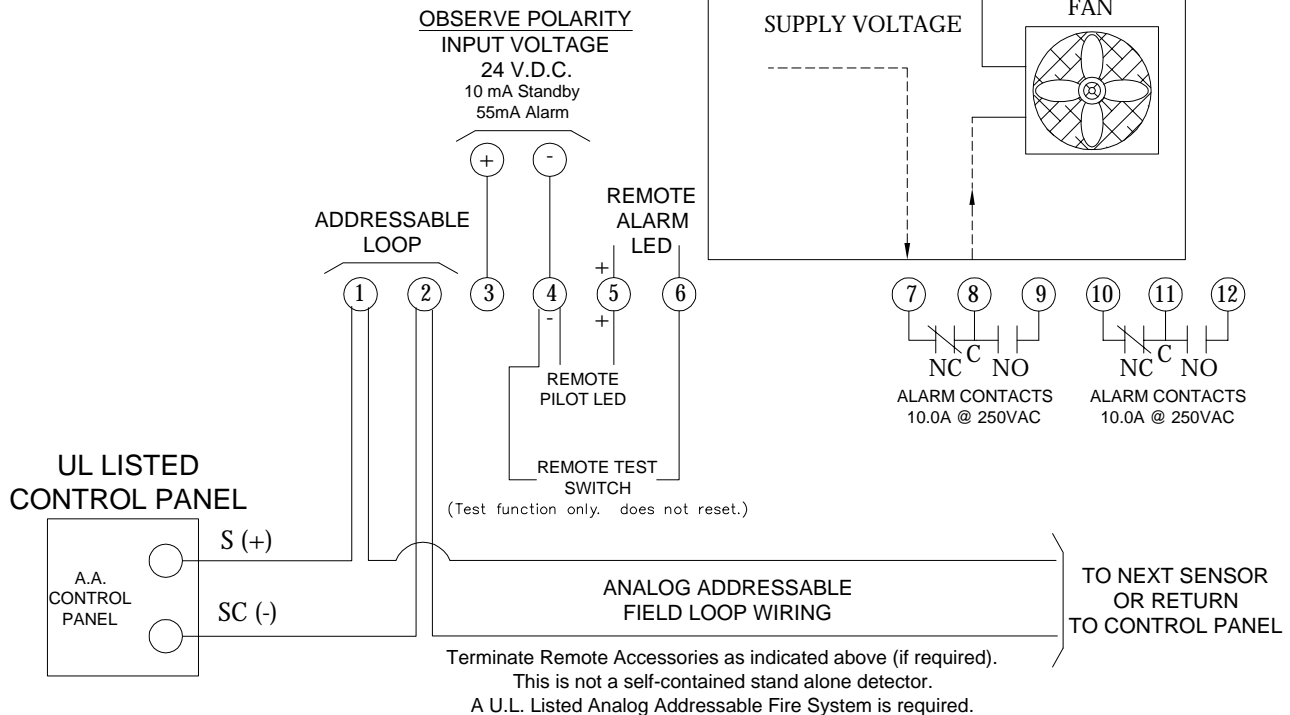

**CAUTION:** Since the analog loop is current limited similar to a conventional two-wire loop, the DH-98-AR cannot be guaranteed to operate under all conditions. This analog duct housing must be treated as a two-wire conventional duct detector when considering auxiliary functions necessary for smoke control. When smoke control is absolutely necessary, the conventional four-wire duct detector (DH-98-P, DH-98-I, DH-98-HVP, DH-98-HVI) used with a contact monitoring module will satisfy the condition.

## FIRE ALARM CONTROL PANEL WIRING

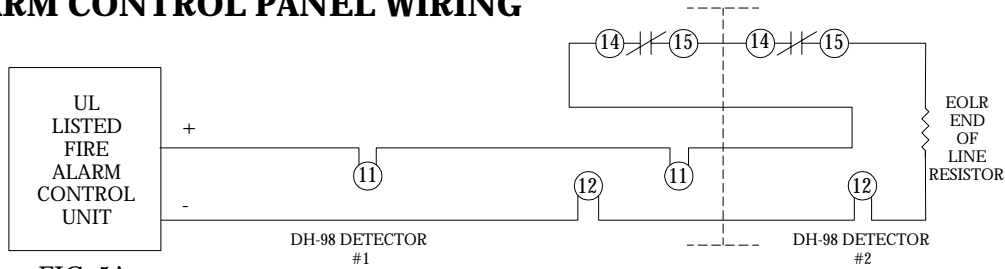
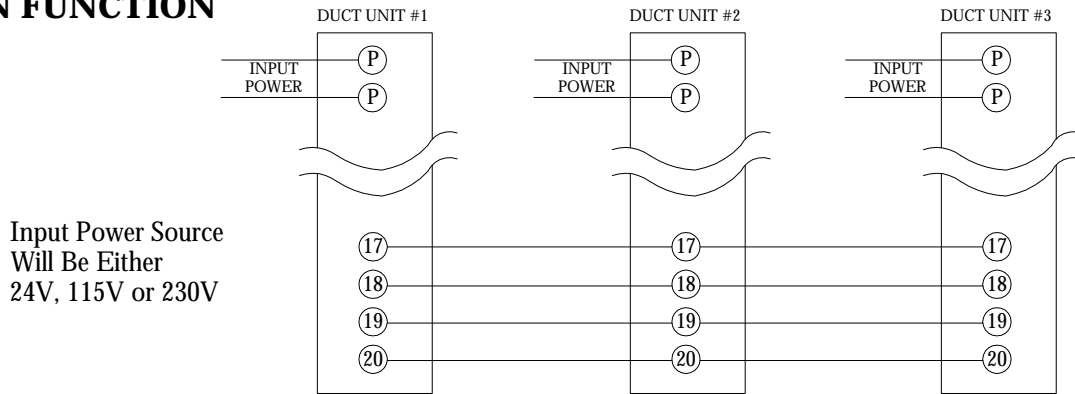

FIG. 5A

## COMMON FUNCTION



Input Power Source  
Will Be Either  
24V, 115V or 230V

FIG. 5B

Installation requiring common functions must be wired as shown in Figure 5B.

Common functions include one or all of the following:

- \* Remote common alarm indication, remote pilot indication, remote common reset, common shutdown and common visual indication.
- \* Common fault indication (when green pilot LED is extinguished) cannot be achieved on the DH-98 Duct Units. Individual Remote Pilot LED's must be installed to monitor detector head or power source removal for each unit.
- \* In the event of an alarm, the detector head and duct unit alarm (Red) LED's will be illuminated. All remaining duct unit alarm LED's will not be illuminated. All remote alarm LED's fitted to the duct units will be illuminated when any of the units go into alarm. Only the duct unit in alarm will permit resetting of the system from the built in test/reset switch on that particular duct unit.
- \* A common Remote reset switch will reset all detectors.

## REMOTE ACCESSORY WIRING

Remote accessory terminals 16 to 20 are not supervised and the output voltage will be present when the duct detector is in alarm or the test/reset switch is operated.

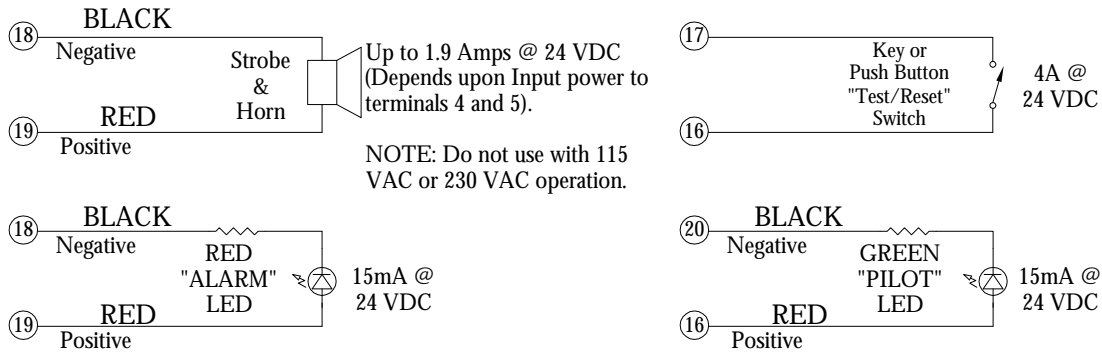

## INTERCONNECT WIRING DIAGRAM (MULTIPLE FAN SHUTDOWN)

DH-98-I, DH-98-P, DH-98-HVI and DH-98-HVP

The DH-98 series duct detectors have the ability to interconnect (all relays operate with a single alarm) using the same independent power supply. Polarity must be observed throughout the connection using terminals 16 and 18 from each unit. Up to 30 units may be interconnected.

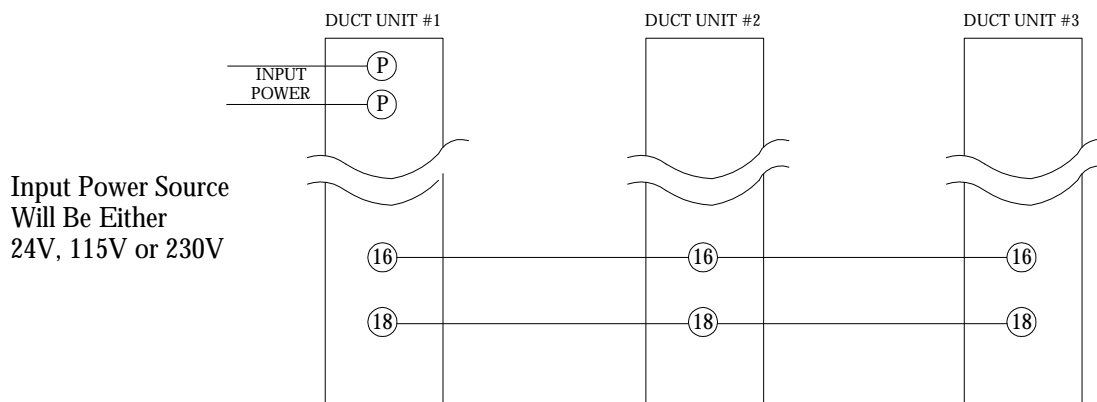

FIG. 7

### HOCHIKI AMERICA CORPORATION

7051 Village Drive Suite 100 \* Buena Park, CA 90621-2268

Phone: 714/522-2246 \* Fax: 714/522-2268

Technical Support: 800/845-6692 or technicalsupport@hochiki.com

